



UNIVERSAL 1200 AUTOMATIC BAGGING MACHINE

IDEAL FOR HIGH PRODUCTIONS

UNIVERSAL 1200



Via del Lavoro, 9
06083 Bastia Umbra



+39 075 8043623



info@mftecno.com



www.mftecno.com



UNIVERSAL 1200

OPEN MOUTH AUTOMATIC BAGGING MACHINE



The UNIVERSAL 1200 automatic bagging machine is the best solution for filling and closing open mouth bags.

The modular structure and movement of the packages in “step-by-step” mode, allows processing of any type of bag and product, with the possibility of coupling it to any closing system and any additional device.

The high speed packaging speed is ensured by the “pendulum” movement of the bag holding and handling devices during the filling and evacuation phases.

The successive traversing of the packages through the various phases of treatment, up to definitive closure, is entrusted to brushless motors controlled by relevant drives.



- 1** Adaptability to different formats, simply and quickly
- 2** The modular structure allows many assembly combinations with space saving
- 3** Bag opening and presentation in a unique solution for increased processing efficiency
- 4** Chain conveyor unit for firmer holding during transport to the closing station



You can watch a video of a working UNIVERSAL 1200 by scanning the QR Code with your phone's camera



OPEN MOUTH AUTOMATIC BAGGING MACHINE



- 5** Compatible with various types of net weight weighing machines with gravity or belt dosing machines, for the different types of product processed
- 6** The parts in contact with the product are in stainless steel
- 7** Automatic control of the correct operating cycle
- 8** Security and access control integrated system

TYPICAL DESIGN

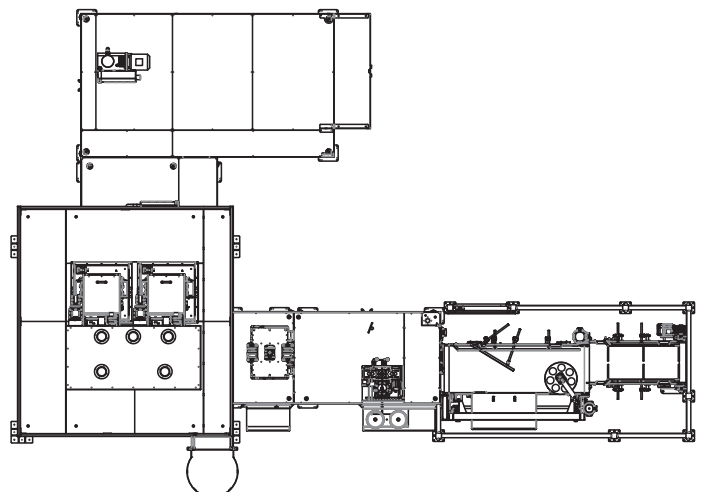
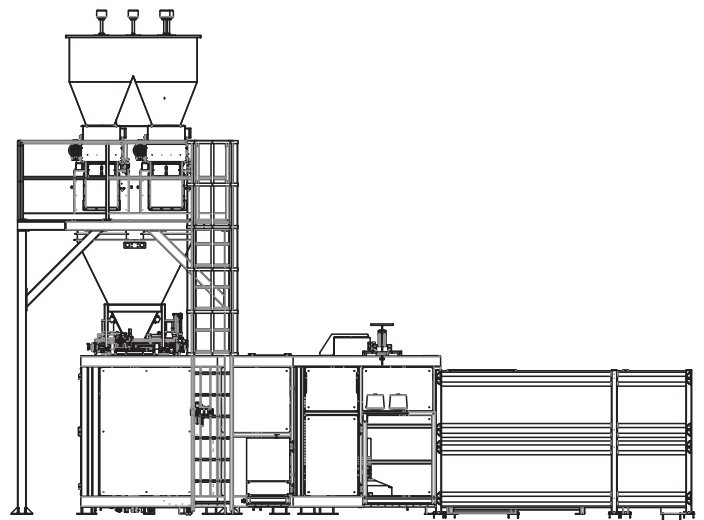
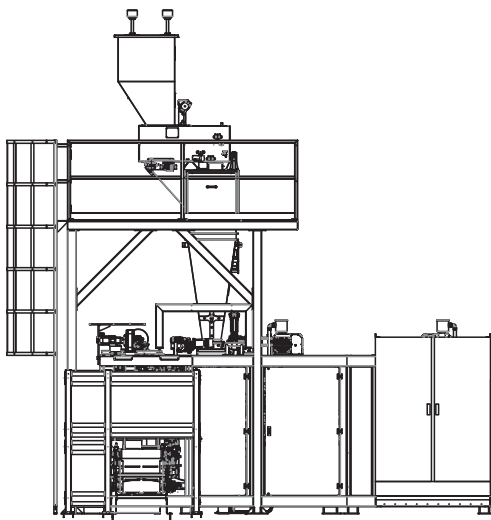

WE CARE FOR YOUR PRODUCT

Manufacturers of Packaging Technologies



**MANUFACTURERS OF COMPLETE PACKAGING PLANTS,
FROM THE BULK PRODUCT TO THE FINISHED PALLET**



*ISO-9001:2015 certified company
Certificate n. 11226-A dated 31-07-2014
issued by KIWA CERMET ITALIA S.p.A.*



*Energy efficiency through
installation of new LED technology
lighting system*



Via del Lavoro, 9
06083 Bastia Umbra



+39 075 8043623



info@mftecno.it

