

FLOW PACK

HORIZONTAL PACKAGING MACHINES



Via del Lavoro, 9
06083 Bastia Umbra



+39 075 8043623



sales@mftecno.com



www.mftecno.com



MARS - RA



- **CONFEZIONATRICE ROTATIVA CON BOBINA DALL'ALTO**
- **FLOW PACK PACKAGING MACHINE WITH FILM REEL FROM THE TOP**
- **ENSACHEUSE HORIZONTALE FLOW-PACK AVEC BOBINE AUTE**
- **ENVASADORA VERTICAL CON BOBINA POR ARRIBA**

Confezionatrice orizzontale automatica flow-pack rotativa con bobina dall'alto. Affidabile e versatile, è adatta a medie e alte produzioni. Può essere abbinata a sistemi di caricamento automatici.

Flow-Pack machine with rotary sealing jaws and top film reel. The reliability and versatility of this machine enable it to meet medium and high production demands. It is available with automatic feeding systems as well.

Machine Flow-Pack avec mâchoires de soudure rotatives et rouleau de film supérieur. La fiabilité et la polyvalence de cette machine lui permettent de répondre à des demandes de production moyennes et élevées. Elle est également disponible avec des systèmes d'alimentation automatique.

Máquina Flow-Pack con mordazas rotativas de sellado y bobina por arriba. La fiabilidad y la versatilidad de esta máquina le permiten satisfacer demandas de producción medias y altas. También está disponible con sistemas de alimentación automática.

HORIZONTAL PACKAGING MACHINES



DETTAGLI | DETAILS | DETALLES | DÉTAILS



MARS - RAE



- **CONFEZIONATRICE ROTATIVA CON BOBINA DALL'ALTO**
- **FLOW PACK PACKAGING MACHINE WITH FILM REEL FROM THE TOP**
- **ENSACHEUSE HORIZONTALE FLOW-PACK AVEC BOBINE AUTE**
- **ENVASADORA VERTICAL CON BOBINA POR ARRIBA**

Confezionatrice orizzontale automatica flow-pack entry level rotativa con bobina dall'alto.

Affidabile e versatile, è adatta a piccole e medie produzioni.

Entry level Flow-Pack machine with rotary sealing jaws and top film reel.

The reliability and versatility of this machine enable it to meet small and medium production demands.

Machine Flow-Pack niveau d'entrée avec mâchoires de soudure rotatives et rouleau de film supérieur.

La fiabilité et la polyvalence de cette machine lui permettent de répondre à des demandes de production petit et moyennes.

Máquina Flow-Pack de nivel básico con mordazas rotativas de sellado y bobina por arriba. La fiabilidad y la versatilidad de esta máquina le permiten satisfacer demandas de producción pequeñas y medias.

HORIZONTAL PACKAGING MACHINES

PRODOTTI | PRODUCTS | PRODUCTOS | PRODUITS



DETTAGLI | DETAILS | DETALLES | DÉTAILS

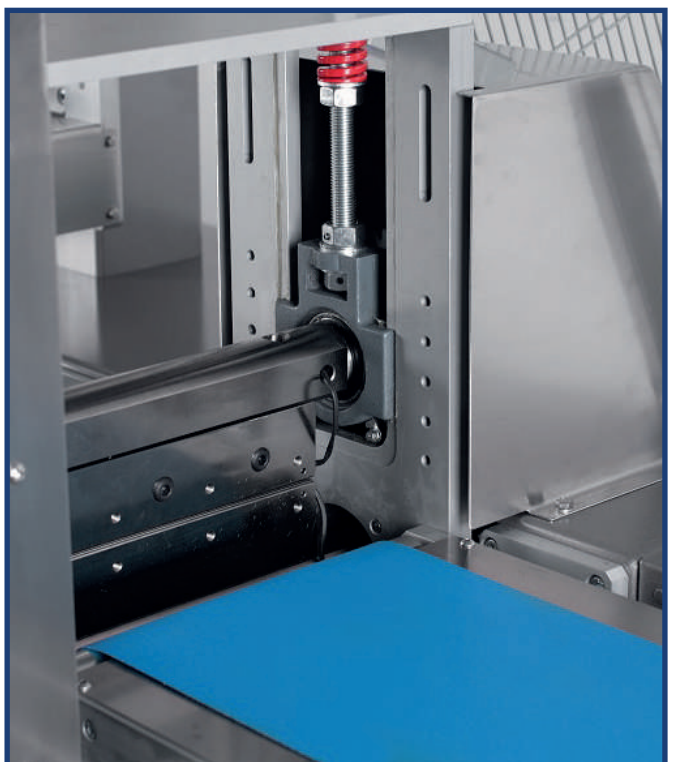

MARS - RB



- **CONFEZIONATRICE ROTATIVA CON BOBINA DAL BASSO**
- **FLOW PACK PACKAGING MACHINE WITH FILM REEL FROM THE BOTTOM**
- **ENSACHEUSE HORIZONTALE FLOW-PACK AVEC BOBINE BASSE**
- **ENVASADORA VERTICAL CON BOBINA POR ABAJO**

Confezionatrice orizzontale automatica flow-pack rotativa con bobina dal basso. Affidabile e versatile, è adatta a medie e alte produzioni. Può essere abbinata a sistemi di caricamento automatici.

Flow-Pack machine with rotary sealing jaws with Film Reel from the bottom. The reliability and versatility of this machine enable it to meet medium and high production demands. It is available with automatic feeding systems as well.

Machine Flow-Pack avec mâchoires de soudure rotatives et rouleau de film en partie basse. La fiabilité et la polyvalence de cette machine lui permettent de répondre à des demandes de production moyennes et élevées. Elle est également disponible avec des systèmes d'alimentation automatique.

Máquina Flow-Pack con mordazas rotativas de sellado y bobina por abajo. La fiabilidad y la versatilidad de esta máquina le permiten satisfacer demandas de producción medias y altas. También está disponible con sistemas de alimentación automática.

HORIZONTAL PACKAGING MACHINE

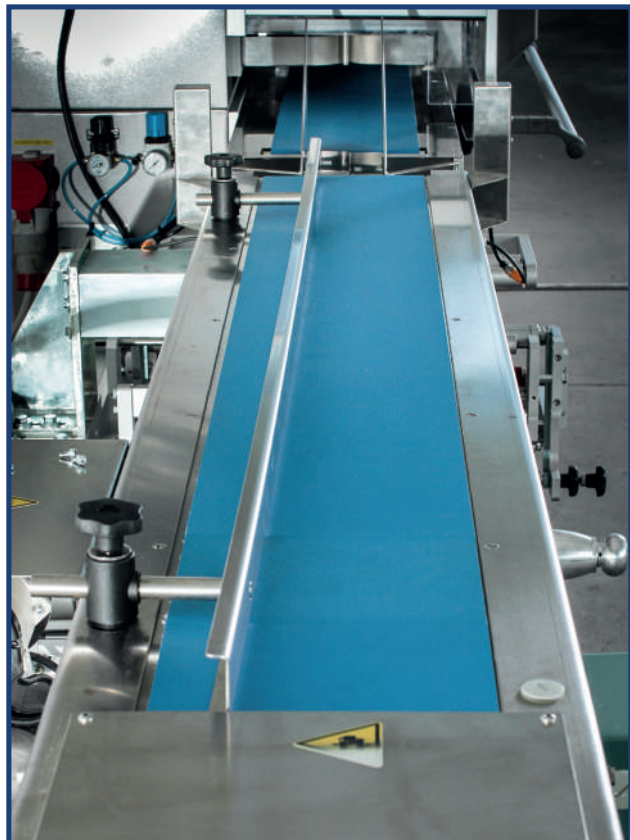

JUPITER - TA



- **CONFEZIONATRICE TRASLANTE CON BOBINA DALL'ALTO**
- **BOX MOTION FLOW PACK MACHINE WITH FILM REEL FROM THE TOP**
- **ENSACHEUSE HORIZONTALE FLOW-PACK MACHOIRE TETE ACCOMPAGNANTE BOBINE HAUTE**
- **ENVASADORA VERTICAL DE LARGA SOLDADURA CON BOBINA POR ARRIBA**

Confezionatrice orizzontale flow-pack traslante con bobina dall'alto completamente elettronica. Affidabile e versatile, è adatta a medie e alte produzioni. Può essere abbinata a sistemi di caricamento automatici e al confezionamento in atmosfera modificata o nebulizzazione di aromi conservanti. A richiesta può essere fornita in versione polietilene.

Electronic box-motion flow-pack machine with film reel from the top. Its main features are reliability and adaptability, which allow the machine to fulfill both medium and high production requirements. It can be combined with automatic loading systems and modified atmosphere packaging (MAP) or preservative flavoring spraying. On request, it can be supplied in polyethylene version.

Ensacheuse horizontale flowpack équipée de barres de soudure accompagnante et d'une bobine de film positionnée en partie haute. Il peut être combiné à des systèmes de chargement automatique et à un conditionnement sous atmosphère modifiée ou à une atomisation des arômes de conservation. Une version en polyéthylène peut être fournie sur demande.

Envasadora flow-pack de larga soldadura con bobina por arriba totalmente electrónica. Fiable y versátil, se adapta con facilidad tanto a las medianas como a las altas capacidades productivas. Opcionalmente, es posible incorporar varios tipos de carga automática y envasar en atmosfera modificada (MAP) para mantener la frescura del producto. Disponible también la versión de polietileno.

HORIZONTAL PACKAGING MACHINE



JUPITER - TB



- **CONFEZIONATRICE TRASLANTE CON BOBINA DAL BASSO**
- **BOX MOTION FLOW PACK MACHINE WITH FILM REEL FROM THE BOTTOM**
- **ENASCHEUSE HORIZONTALE TÊTE ACCOMPAGNANTE BOBINE BASSE**
- **ENVASADORA FLOW PACK DE LARGA SOLDADURA CON BOBINA POR ABAJO**

Confezionatrice orizzontale flow-pack traslante con bobina dal basso completamente elettronica. Affidabile e versatile, è adatta a medie e alte produzioni.

Può essere abbinata a sistemi di caricamento automatici e al confezionamento in atmosfera modificata o nebulizzazione di aromi conservanti.

A richiesta può essere fornita in versione polietilene.

Electronic box-motion flow-pack machine with film reel from the top. Its main feature are reliability and adaptability, which allow the machine to fulfill both medium and high production requirements. It can be combined with automatic loading systems and modified atmosphere packaging (MAP) or preservative flavoring spraying.

On request, it can be supplied in polyethylene version.

Ensacheuse horizontale flowpack équipée de barres de soudure accompagnante et d'une bobine de film positionnée en partie haute.

Il peut être combiné à des systèmes de chargement automatique et à un conditionnement sous atmosphère modifiée ou à une atomisation des arômes de conservation.

Une version en polyéthylène peut être fournie sur demande.

Envasadora flow-pack de larga soldadura con bobina por arriba totalmente electronica. Fiable y versatil, se adapta con facilidad tanto a las medianas como a las altas capacidades productivas. Opcionalmente, es posible incorporar varios tipos de carga automatica y envasar en atmosfera modifcada (MAP) para mantener la frescura del producto. Disponible también la version de polietileno.

HORIZONTAL PACKAGING MACHINES

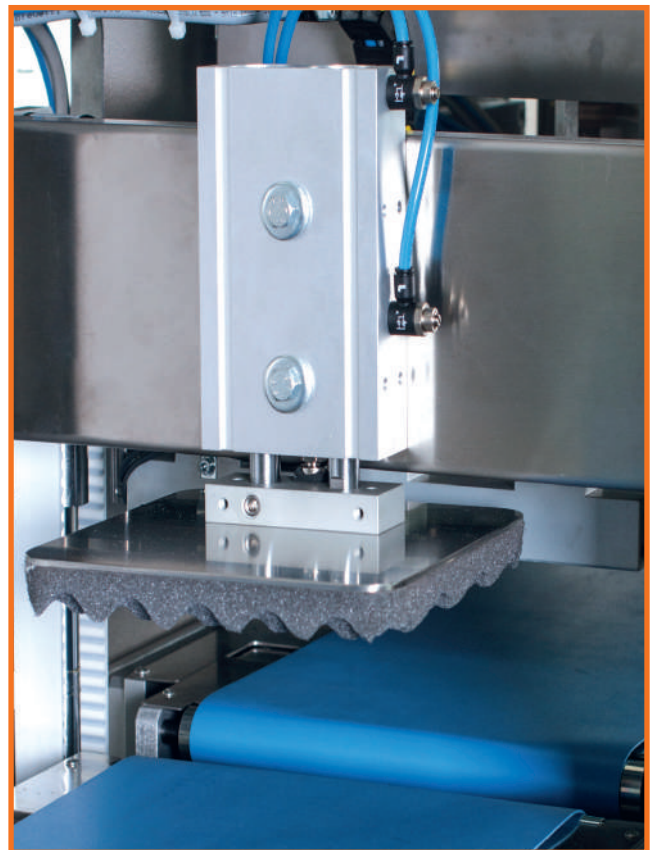

PACKAGING LINES



HORIZONTAL PACKAGING MACHINES



- **LINEE COMPLETE DI PACKAGING**
- **COMPLETE PACKAGING LINES**
- **SYSTÈMES D'EMBALLAGE COMPLETS**
- **SISTEMAS COMPLETOS DE EMBALAJE**





- **SISTEMA COMPLETO PER CIOCCOLATINI**
- **COMPLETE SYSTEM FOR CHOCOLATES**
- **SYSTÈME COMPLET POUR CHOCOLATS**
- **SISTEMA COMPLETO PARA CHOCOLATES**



HORIZONTAL PACKAGING MACHINES



- **SISTEMA COMPLETO PER BISCOTTI**
- **COMPLETE SYSTEM FOR BISCUITS**
- **SYSTÈME COMPLET DE BISCUITS**
- **SISTEMA COMPLETO DE GALLETAS**





- **SISTEMA COMPLETO PER POMODORI**
- **COMPLETE SYSTEM FOR TOMATOES**
- **SYSTÈME COMPLET POUR LES TOMATES**
- **SISTEMA COMPLETO PARA TOMATES**





- **SISTEMA COMPLETO PER PASTIGLIE**
- **COMPLETE SYSTEM FOR TABLETS**
- **SYSTÈME COMPLET POUR LES TABLETTES**
- **SISTEMA COMPLETO PARA TABLETAS**







- **SISTEMA COMPLETO PER GALLETTE DI RISO**
- **COMPLETE SYSTEM FOR RICE CAKES**
- **SYSTÈME COMPLET POUR LES GÂTEAUX DE RIZ**
- **SISTEMA COMPLETO PARA PASTELES DE ARROZ**



TECHNICAL FEATURES

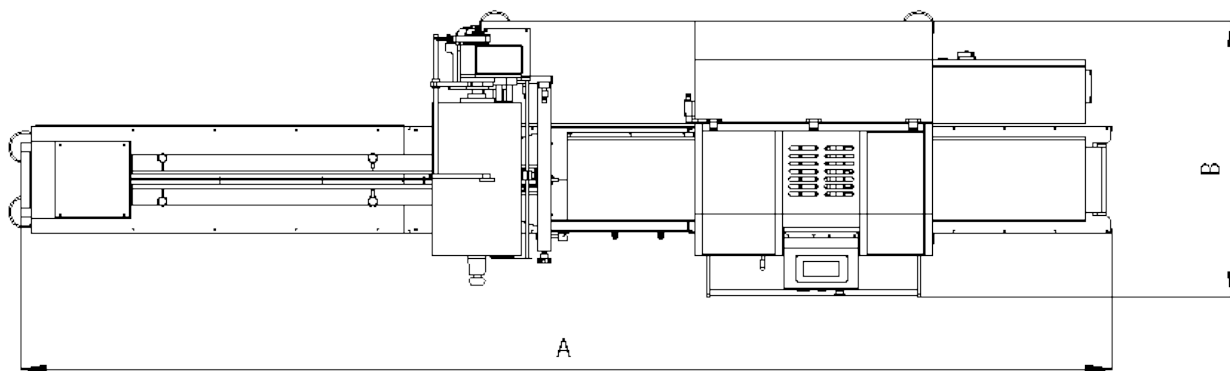



- **CARATTERISTICHE TECNICHE**
- **TECHNICAL FEATURES**
- **CARACTÉRISTIQUES TECHNIQUES**
- **CARACTERÍSTICAS TÉCNICAS**

MARS-RAE

Confezionatrice rotativa con bobina dall'alto

- Struttura in ferro verniciato e carter in acciaio
- Parti a contatto col prodotto in acciaio inox
- Nastro di alimentazione a palette da 1600 mm
- Saldatura longitudinale a 2 coppie di ruote
- Saldatore trasversale rotativo
- Porta-bobina a espansione
- Tappeto di uscita motorizzato
- 3 motori brushless
- Pannello di comando con touch screen HD da 4,3"

Rotary jaws flow pack machine with film roll from the top

- Main machine structure in steel with covers in stainless steel
- Product contact parts in stainless steel
- 1600 mm long infeed conveyor with nylon pushers
- 2 sets of wheels for longitudinal sealing
- Transverse rotary sealing jaw
- Reel holder with expanding shaft
- Discharge conveyor belt complete of AC motor
- 3 brushless servomotors
- Control panel with a 4,3" HD touch screen

Ensacheuse horizontale flow-pack machoire rotative bobine haute

- Structure machine en acier peint, carters en acier inox
- Pièces en contact avec le produit en acier inox
- Convoyeur d'alimentation à taquets en nylon L=1600mm
- Soudure longitudinale avec 2 jeux de molettes
- Mâchoires de soudure transversale rotatives
- Porte-bobine à expansion
- Tapis de sortie avec moteur asynchrone
- 3 moteurs brushless
- Panneau de commande avec écran tactile HD 4,3"

Envasadora flow pack de mordaza rotativa y bobina por arriba

- Construcción en hierro barnizado y cárter en acero inoxidable
- Partes en contacto con el producto en acero inoxidable
- Carro de alimentación L=1600 mm
- Sistema de soldadura longitudinal compuesto por 2 parejas de ruedas
- Sistema de soldadura transversal rotativo
- Porta bobina con expansión
- Cinta de salida motorizada mediante motor AC
- 3 motorizaciones brushless
- Panel de control con pantalla táctil HD 4.3"

Accessori

- Fotocellula di centratura del film stampato
- Stampatori
- Saldatore trasversale a più settori
- Sistemi di trasporto speciali
- Coltello a zig-zag
- Euroslot
- Versione Full Inox

Optionals

- Photocell for print registered film
- Printers
- Two or more up-jaws
- Special loading systems
- Zig-zag knives
- Euroslot die cutting system
- Full Inox version

Options

- Photocellule pour film imprimé repéré
- Marqueurs
- Deux ou plus secteurs mâchoire transversale
- Systèmes de chargement spéciaux
- Couteaux Zig-zag
- Trou européen (Euroslot)
- Version inox

Accesorios

- Fotocélula para centrado de film impreso
- Fechadores
- Mordaza de dos sectores o más
- Sistemas de transporte especiales
- Cuchillo zig-zag
- Euroslot
- Versión inoxidable

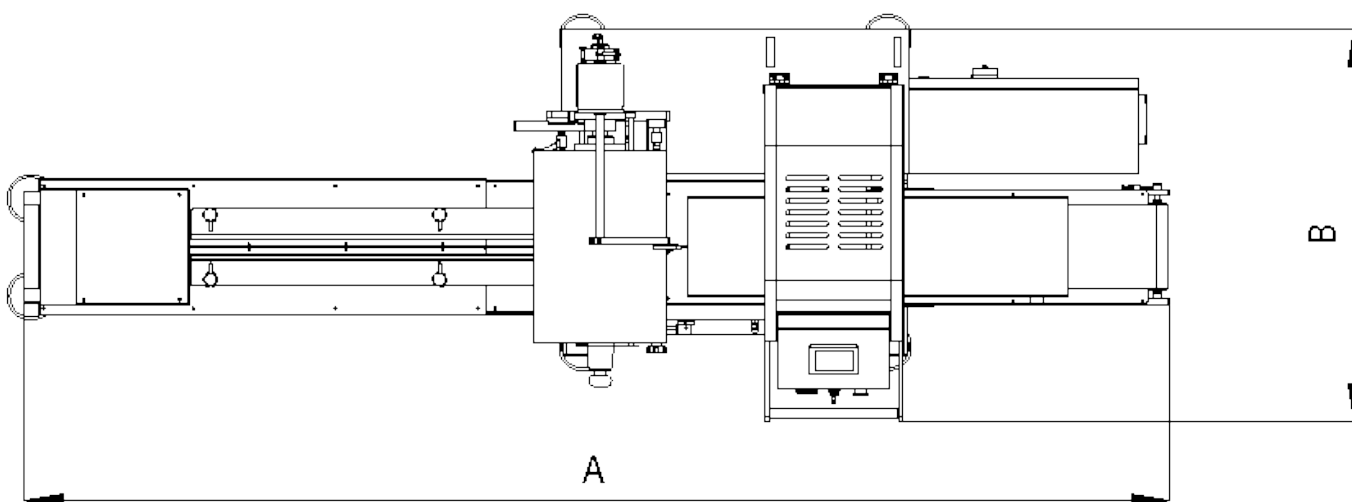

	A	B					V
MARS-RAE	3000 mm	1050 mm	500 mm	50-600 mm	120 mm	max 120/min	400V - 3ph - 50 Hz

MARS-RA

Confezionatrice rotativa con bobina dall'alto

- Struttura in ferro verniciato e carter in acciaio
- Parti a contatto col prodotto in acciaio inox
- Nastro di alimentazione a palette da 2000 mm
- Saldatura longitudinale a 3 coppie di ruote
- Saldatore trasversale rotativo
- Porta-bobina a espansione pneumatica
- Tappeto di uscita motorizzato
- 3 motori brushless
- Pannello di comando con touch screen HD 7"
- Teleassistenza

Rotary jaws flow pack machine with film roll from the top

- Main machine structure in steel with covers in stainless steel
- Product contact parts in stainless steel
- 2000 mm long infeed conveyor with nylon pushers
- 3 sets of wheels for longitudinal sealing
- Transverse rotary sealing jaw
- Reel holder with air expanding shaft
- Discharge conveyor belt complete of AC motor
- 3 brushless servomotors
- Control panel with a 7" HD touch screen
- Remote maintenance

Ensacheuse horizontale flow-pack machoire rotative bobine haute

- Structure machine en acier peint, carters en acier inox
- Pièces en contact avec le produit en acier inox
- Convoyeur d'alimentation à taquets en nylon L=2000mm
- Soudure longitudinale avec 3 jeux de molettes
- Mâchoires de soudure transversale rotatives
- Porte-bobine à expansion pneumatique
- Tapis de sortie avec moteur asynchrone
- 3 moteurs brushless
- Panneau de commande avec écran tactile HD 7"
- Téléassistance

Envasadora flow pack de mordaza rotativa y bobina por arriba

- Construcción en hierro barnizado y carter en acero inoxidable
- Partes en contacto con el producto en acero inoxidable
- Carro de alimentación L=2000 mm
- Sistema de soldadura longitudinal compuesto por 3 parejas de ruedas
- Sistema de soldadura transversal rotativo
- Porta bobina con expansión neumática
- Cinta de salida motorizada mediante motor AC
- 3 motorizaciones brushless
- Panel de control con pantalla táctil HD 7"
- Tele asistencia

Accessori

- Fotocellula di centratura del film stampato
- Stampatori
- Saldatore trasversale a più settori
- Sistemi di trasporto speciali
- Coltello a zig-zag
- Euroslot
- Versione Full Inox

Optionals

- Photocell for print registred film
- Printers
- Two or more up-jaws
- Special loading systems
- Zig-zag knives
- Euroslot die cutting system
- Full Inox version

Options

- Photocellule pour film imprimé repéré
- Marqueurs
- Deux ou plus secteurs mâchoire transversale
- Systèmes de chargement spéciaux
- Couteaux Zig-zag
- Trou européen (Euroslot)
- Version inox

Accesorios

- Fotocélula para centrado de film impreso
- Fechadores
- Mordaza de dos sectores o más
- Sistemas de transporte especiales
- Cuchillo zig-zag
- Euroslot
- Versión inoxidable

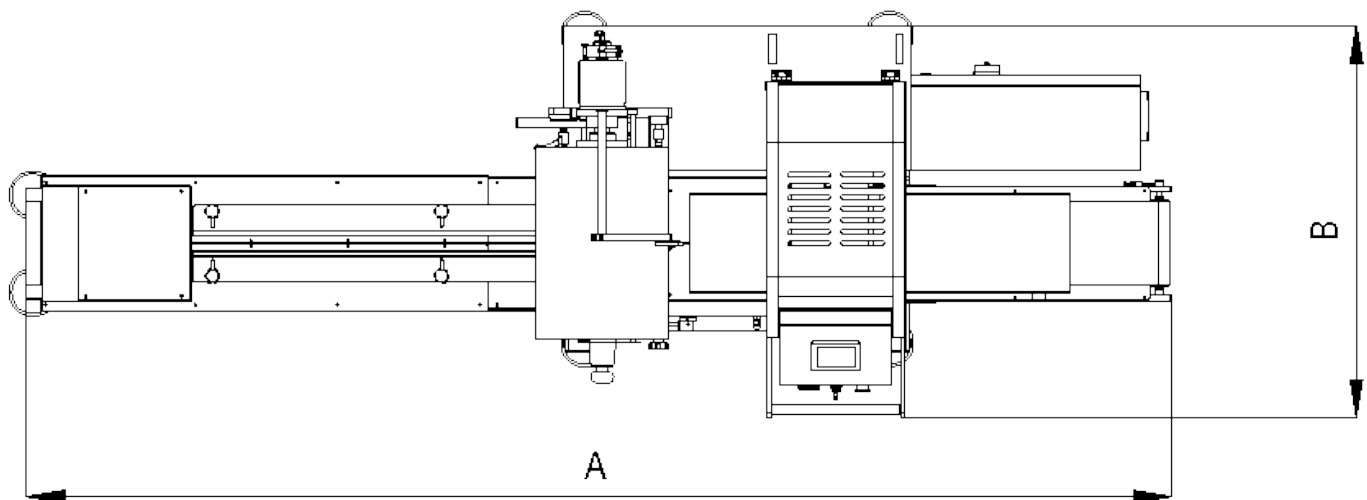

	A	B					V
MARS-RA 50	3800 mm	1000 mm	500 mm	50-600 mm	120 mm	max 120/min	400V - 3ph - 50 Hz
MARS-RA 60	3800 mm	1050 mm	600 mm	50-600 mm	120 mm	max 120/min	400V - 3ph - 50 Hz
MARS-RA 70	3800 mm	1150 mm	700 mm	50-600 mm	120 mm	max 120/min	400V - 3ph - 50 Hz

MARS-RB

Confezionatrice rotativa con bobina dal basso

- Struttura in ferro verniciato e carter in acciaio
- Parti a contatto col prodotto in acciaio inox
- Nastro di alimentazione a palette da 2000 mm
- Saldatura longitudinale a 3 coppie di ruote
- Saldatore trasversale rotativo
- Porta-bobina a espansione pneumatica
- Tappeto di uscita motorizzato
- 4 motori brushless
- Svolgimento bobina motorizzato
- Pannello di comando con touch screen HD 7"
- Teleassistenza

Accessori

- Fotocellula di centratura del film stampato
- Fotocellula "no product no bag"
- Nastro di alimentazione a telo piano
- Apertura pneumatica automatica delle ruote di saldatura longitudinale
- Stampatori
- Posa-etichette ed etichettatrici
- Saldatore trasversale a più settori
- Doppio porta-bobina
- Giunzione bobina automatica
- Sistemi di alimentazione automatica
- Coltello a zig-zag
- Euroslot
- Versione Full Inox

Rotary jaws flow pack machine with film roll from the bottom

- Machine structure in steel with covers in stainless steel
- Product contact parts in stainless steel
- 2000 mm long infeed conveyor with nylon pushers
- 3 sets of wheels for longitudinal sealing
- Transverse rotary sealing jaw
- Reel holder with air expanding shaft
- Discharge conveyor belt complete of AC motor
- 4 brushless servo motors
- Motorised film unwinding
- Control panel with a 7" HD touch screen
- Remote maintenance

Optionals

- Photocell for print registered film
- Photocell "no product no bag"
- Belted infeed conveyor
- Pneumatic opening of wheels (longitudinal sealing)
- Printers
- Labelling devices
- Two or more up-jaws
- Double film reel holder
- Automatic film splicer
- Automatic feeding systems
- Zig-zag knife
- Euroslot die cutting system
- Full Inox version

Ensacheuse horizontale flow-pack machoire rotative bobine basse

- Structure machine en acier peint, carters en acier inox
- Pièces en contact avec le produit en acier inox
- Convoyeur d'alimentation à taquets en nylon L=2000mm
- Soudure longitudinale avec 3 jeux de molettes
- Mâchoires transversale rotatives
- Porte-bobine à expansion pneumatique
- Tapis de sortie avec moteur asynchrone
- 4 moteurs brushless
- Déroulement film motorisé
- Panneau de commande avec écran tactile HD 7"
- Téléassistance

Options

- Photocellule pour film imprimé repéré
- Photocellule "Pas de produit-pas de sachet"
- Bande d'alimentation avec tapis lisse
- Ouverture pneumatique molettes de soudure longitudinale
- Marqueurs
- Etiqueteuses
- Deux ou plus secteurs mâchoire transversale
- Double portebobine avec raccord automatique
- Systèmes d'alimentation automatique
- Couteaux Zig-zag
- Trou européen (Euroslot)
- Version inox

Envasadora flow pack de mordaza rotativa y bobina por abajo

- Construcción en hierro barnizado y cárter en acero inoxidable
- Partes en contacto con el producto en acero inoxidable
- Carro de alimentación L=2000 mm
- Sistema de soldadura longitudinal compuesto por 3 parejas de ruedas
- Sistema soldadura transversal rotativo
- Portabobina con expansión neumática
- Cinta de salida motorizada mediante motor AC
- 4 motorizaciones brushless
- Desbobinador motorizado
- Panel de control con pantalla táctil HD 7"
- Tele asistencia

Accesorios

- Fotocélula para centrado de film impreso
- Fotocélula "no producto no bolsa"
- Carro de alimentación de cinta llana
- Apertura neumática automática de rodillos de soldadura longitudinal
- Fechadores
- Etiquetadoras
- Mordaza de dos sectores o más
- Doble porta-bobina
- Cambio de bobina automático
- Alimentadores automáticos
- Cuchillo zig-zag
- Euroslot
- Versión inoxidable

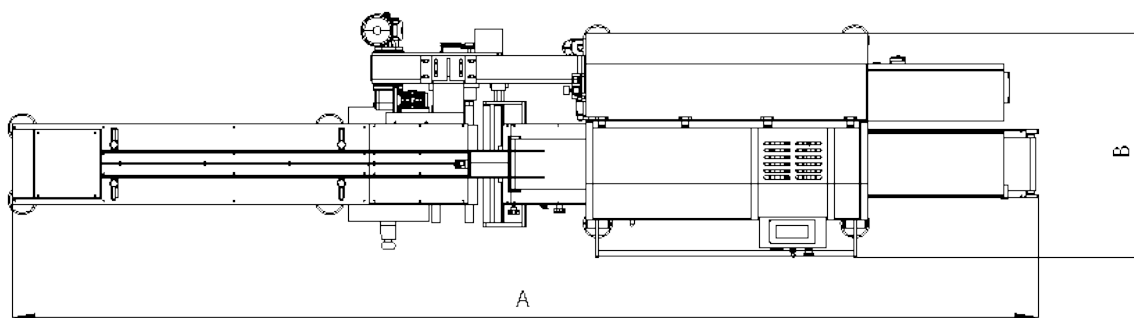

	A	B					V
MARS-RB 50	4510 mm	1000 mm	500 mm	50-600 mm	120 mm	max 120/min	400V - 3ph - 50Hz
MARS-RB 60	4510 mm	1050 mm	600 mm	50-600 mm	120 mm	max 120/min	400V - 3ph - 50Hz
MARS-RB 70	4510 mm	1150 mm	700 mm	50-600 mm	120 mm	max 120/min	400V - 3ph - 50Hz

JUPITER-TA

Confezionatrice traslante con bobina dall'alto

- Struttura in ferro verniciato e carter in acciaio
- Parti a contatto col prodotto in acciaio inox
- Nastro di alimentazione a palette da 2000 mm
- Pattini preriscaldamento film
- Saldatura longitudinale a 3 coppie di ruote con apertura pneumatica automatica
- Saldatore trasversale a moto traslante continuo
- Porta-bobina a espansione pneumatica
- Tappeto di uscita motorizzato
- 4 motori brushless
- Pannello di comando con touch screen HD 7"
- Teleassistenza

Box motion flow pack machine with film roll from the top

- Main machine structure in steel with covers in stainless steel
- Product contact parts in stainless steel
- 2000 mm long infeed conveyor with nylon pushers
- 3 sets of wheels for longitudinal sealing
- Transverse rotary sealing jaw
- Reel holder with air expanding shaft
- Discharge conveyor belt complete of AC motor
- 4 brushless servomotors
- Control panel with a 7" HD touch screen
- Remote maintenance

Ensacheuse flow-pack machoire tete accompagnante bobine haute

- Structure machine en acier peint, carters en acier inox
- Pièces en contact avec le produit en acier inox
- Convoyeur d'alimentation à taquets en nylon L=2000mm
- Soudure longitudinale avec 3 jeux de molettes
- Mâchoires de soudure transversale rotatives
- Porte-bobine à expansion pneumatique
- Tapis de sortie avec moteur asynchrone
- 4 moteurs brushless
- Panneau de commande avec écran tactile HD 7"
- Téléassistance

Envasadora flow pack de larga soldadura con bobina por arriba

- Construcción en hierro barnizado y carter en acero inoxidable
- Partes en contacto con el producto en acero inoxidable
- Carro de alimentación L=2000 mm
- Sistema de soldadura longitudinal compuesto por 3 parejas de ruedas
- Sistema de soldadura transversal rotativo
- Porta bobina con expansión neumática
- Cinta de salida motorizada mediante motor AC
- 4 motorizaciones brushless
- Panel de control con pantalla táctil HD 7"
- Tele asistencia

Accessori

- Fotocellula di centratura del film stampato
- Fotocellula "no product no bag"
- Stampatori
- Kit confezionamento atmosfera modificata
- Tampone pneumatico sul taglia-cuce
- Posa-etichette ed etichettatrici
- Doppio porta-bobina
- Giunzione bobina automatica
- Sistemi di alimentazione automatica
- Euroslot
- Versione poly (saldatura politene)
- Versione Full Inox

Optionals

- Photocell for print registered film
- Photocell "no product no bag"
- Printers
- M.A.P. pre-setting (gas flushing)
- Pneumatic pressing unit
- Labelling devices
- Double film reel holder
- Automatic film splicer
- Automatic feeding systems
- Euroslot die cutting system
- Poly version
- Full Inox version

Options

- Photocellule pour film imprimé repéré
- Photocellule "Pas de produit-pas de sachet"
- Marqueurs
- Prédiposition pour travailler en atmosphère modifiée
- Presseur pneumatique dans la TST
- Etiqueteuses
- Double portebobine
- Double portebobine avec raccord automatique
- Systèmes d'alimentation automatique
- Trou européen (Euroslot)
- Version polyéthylène
- Version inox

Accesorios

- Fococélula para centrado de film impreso
- Fococélula "no producto no bolsa"
- Fechadores
- Kit gas (atmosfera modificada)
- Tampón neumático a la salida del producto
- Etiquetadoras
- Doble porta-bobina
- Cambio de bobina automático
- Alimentadores automáticos
- Euroslot
- Versión politene
- Versión inoxidable

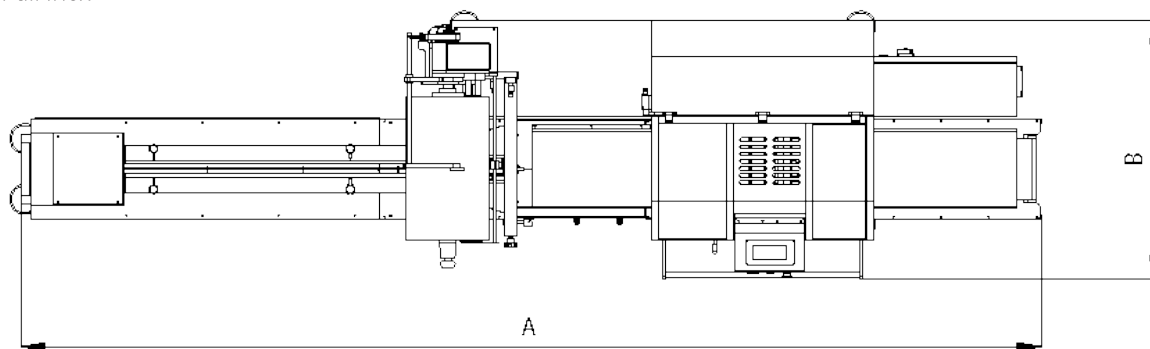

	A	B					V
JUPITER-TA 60	4300 mm	1100 mm	600 mm	50-600 mm	160 mm	max 60/min	400V-3ph-50Hz
JUPITER-TA 70	4300 mm	1200 mm	700 mm	50-600 mm	160 mm	max 60/min	400V-3ph-50Hz

JUPITER-TB

Confezionatrice traslante con bobina dal basso

- Struttura in ferro verniciato e carter in acciaio
- Parti a contatto col prodotto in acciaio inox
- Nastro di alimentazione a palette da 2000 mm
- Pattini preriscaldamento film
- Saldatura longitudinale a 3 coppie di ruote con apertura pneumatica automatica
- Saldatore trasversale a moto traslante continuo
- Porta-bobina a espansione pneumatica
- Tappeto di uscita motorizzato
- 5 motori brushless
- Pannello di comando con touch screen HD 7"
- Teleassistenza

Box motion flow pack machine with film roll from the bottom

- Main machine structure in steel with covers in stainless steel
- Product contact parts in stainless steel
- 2000 mm long infeed conveyor with nylon pushers
- 3 sets of wheels for longitudinal sealing
- Transverse rotary sealing jaw
- Reel holder with air expanding shaft
- Discharge conveyor belt complete of AC motor
- 5 brushless servomotors
- Control panel with a 7" HD touch screen
- Remote maintenance

Ensacheuse flow-pack machoire tete accompagnante bobine basse

- Structure machine en acier peint, carters en acier inox
- Pièces en contact avec le produit en acier inox
- Convoyeur d'alimentation à taquets en nylon L=2000mm
- Soudure longitudinale avec 3 jeux de molettes
- Mâchoires de soudure transversale rotatives
- Porte-bobine à expansion pneumatique
- Tapis de sortie avec moteur asynchrone
- 5 moteurs brushless
- Panneau de commande avec écran tactile HD 7"
- Télassistance

Envasadora flow pack de larga soldadura con bobina por abajo

- Construcción en hierro barnizado y carter en acero inoxidable
- Partes en contacto con el producto en acero inoxidable
- Carro de alimentación L=2000 mm
- Sistema de soldadura longitudinal compuesto por 3 parejas de ruedas
- Sistema de soldadura transversal rotativo
- Porta bobina con expansión neumática
- Cinta de salida motorizada mediante motor AC
- 5 motorizaciones brushless
- Panel de control con pantalla táctil HD 7"
- Tele asistencia

Accessori

- Fotocellula di centratura del film stampato
- Fotocellula "no product no bag"
- Stampatori
- Kit confezionamento atmosfera modificata
- Tampone pneumatico sul taglia-cuce
- Posa-etichette ed etichettatrici
- Doppio porta-bobina
- Giunzione bobina automatica
- Sistemi di alimentazione automatica
- Euroslot
- Versione poly (saldatura politene)
- Versione Full Inox

Optionals

- Photocell for print registered film
- Photocell "no product no bag"
- Printers
- M.A.P. pre-setting (gas flushing)
- Pneumatic pressing unit
- Labelling devices
- Double film reel holder
- Automatic film splicer
- Automatic feeding systems
- Euroslot die cutting system
- Poly version
- Full Inox version

Options

- Photocellule pour film imprimé repéré
- Photocellule "Pas de produit-pas de sachet"
- Marqueurs
- Prédiposition pour travailler en atmosphère modifiée
- Presseur pneumatique dans la TST
- Etiqueteuses
- Double portebobine
- Double portebobine avec raccord automatique
- Systèmes d'alimentation automatique
- Trou européen (Euroslot)
- Version polyéthylène
- Version inox

Accesorios

- Fotocélula para centrado de film impreso
- Fotocélula "no producto no bolsa"
- Fechadores
- Kit gas (atmosfera modificada)
- Tampón neumático a la salida del producto
- Etiquetadoras
- Doble porta-bobina
- Cambio de bobina automático
- Alimentadores automáticos
- Euroslot
- Versión politene
- Versión inoxidable

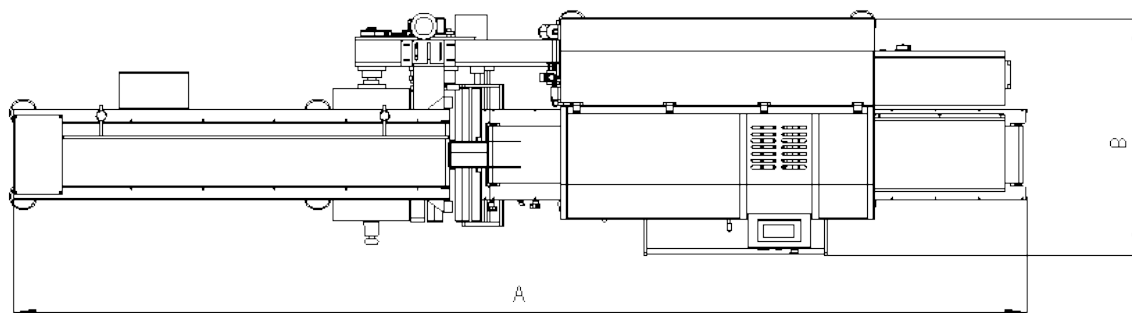

	A	B					V
JUPITER-TB 60	4700 mm	1100 mm	600 mm	50-600 mm	160 mm	max 60/min	400V - 3ph - 50Hz
JUPITER-TB 70	4700 mm	1200 mm	700 mm	50-600 mm	160 mm	max 60/min	400V - 3ph - 50Hz



***COSTRUTTORI DI MACCHINARI DI PACKAGING,
DAL PRODOTTO SFUSO AL PALLET FINITO.***

***MANUFACTURERS OF PACKAGING MACHINERY,
FROM BULK PRODUCTS TO FINISHED PALLETS.***

***FABRICANTS DE MACHINES D'EMBALLAGE,
DU PRODUIT EN VRAC À LA PALETTE FINIE.***

***FABRICANTES DE MAQUINARIA DE ENVASADO,
DESDE EL PRODUCTO A GRANEL HASTA EL PALÉ
TERMINADO.***



WE CARE FOR YOUR PRODUCT



MANUFACTURERS OF PACKAGING TECHNOLOGIES



ISO-9001:2015 certified company
Certificate n. 11226-A dated 31-07-2014
issued by KIWA CERMET ITALIA S.p.A.



Energy efficiency through
installation of new LED technology
lighting system



Via del Lavoro, 9
06083 Bastia Umbra



+39 075 8043623



sales@mftecno.com



www.mftecno.com

